



Product Features

- Heavy duty industrial construction
- Forward curved centrifugal blower
- High Temperature ball bearing motor
- Optional replaceable filter
- Single point power connection
- 24 volt control
- Heavy duty spiral finned elements constructed of stainless steel
- Safety devices include airflow switch, automatic limit control and manual reset limit control for secondary protection
- Disconnect switch and Unit Mounted Thermostat with range of up to 120 to 150 degrees F°
- The "TAT" series is sold as a system that includes the base unit, three supplemental units and the remote timer/ temperature control (supplemental units may be purchased seperately if necessary)

Product Specifications

APPLICATIONS:

- The "TAT" series is designed to heat small and mid-sized rooms up to 150 degrees F. This provides effective portable heating to areas infected with insects. It kills adult insects and will dehydrate larvae and eggs, making them unable to hatch. Although chemical sprays only target adult insects, they can be used before utilizing the "TAT" system in order to kill the adult insects.
- The system is designed to bring the temperature up to 150 degrees F in one hour or less, if all preliminary requirements are met.
- The "TAT" system may be used for water remediation, as well, in combination with adequate ventilation. Specific models for water remediation are also available.

TAT BASE UNIT:

- Heavy duty stainless steel spiral fin heating elements
- High temperature, ball bearing 1/3 hp - 1075 rpm blower motor
- Forward curved centrifugal blower-900 cfm of air output
- Safety devices include airflow switch, disconnect switch, automatic limit control and manual reset limit control for secondary protection
- 50 amp unit may be linked to a 30 amp unit to provide heating for larger spaces.
- Timer/Temp controller may be used to control both units but must use the 50 amp base unit as the master.

SUPPLEMENTAL TAT CONVECTORS

3 convectors are an integral part of each TAT system

- 120 volt, 15 amp (Standard wall plug) - 5120 BTU size
- Supplied with 25' prewired cable that connects them to the TAT base unit control section with a three pin connector
- If used in front of windows or large glass doors, they will reduce heat loss and provide more even heating

TIMER/TEMPERATURE CONTROL UNIT

Timer/Temp Controller is an integral part of the TAT system

- 24 volt control device that controls the heat output of the TAT base unit and up to three TAT convectors for an operating range of 120 - 150 degrees F and for a time period of 1 -10 hours after the preset temperature is reached
- Supplied with a 25' prewired cable that connects to the TAT base unit control section using a four pin connector
- Mounts on Door outside the area being treated.
- LED lights will indicate when treatment is complete

Thermal Area Treatment Heaters

Standard Models

UPC# 686334	MODEL	KW	BTU'S	VOLTS	PHASE	AMPS	PLUG TYPE	LIST
397506	TAT-8-240-1	8.4	28670	240	1	37	Nema 14-50	11,250
397513	TAT-5-240-1	5.3	18089	240	1	24	Nema 10-30	10,500
397520	TAT-20-480-3	20.0	68260	480	3	26	Nema L16-30	13,125
397537	TAT-1-120-1	1.5	5120	120	1	12.5	Nema 5-15	1875
397551	Style / TAT-8 W/3 TAT/1 TIMER	----	----	----	----	----	----	16,875
397568	Style / TAT-5 W/3 TAT/1 TIMER	----	----	----	----	----	----	16,125
397575	Style / TAT-20 W/3 TAT/1 TIMER	----	----	----	----	----	----	18,750
397582	TAT-ILC 25	---	----	----	----	----	----	750

Product Dimensions

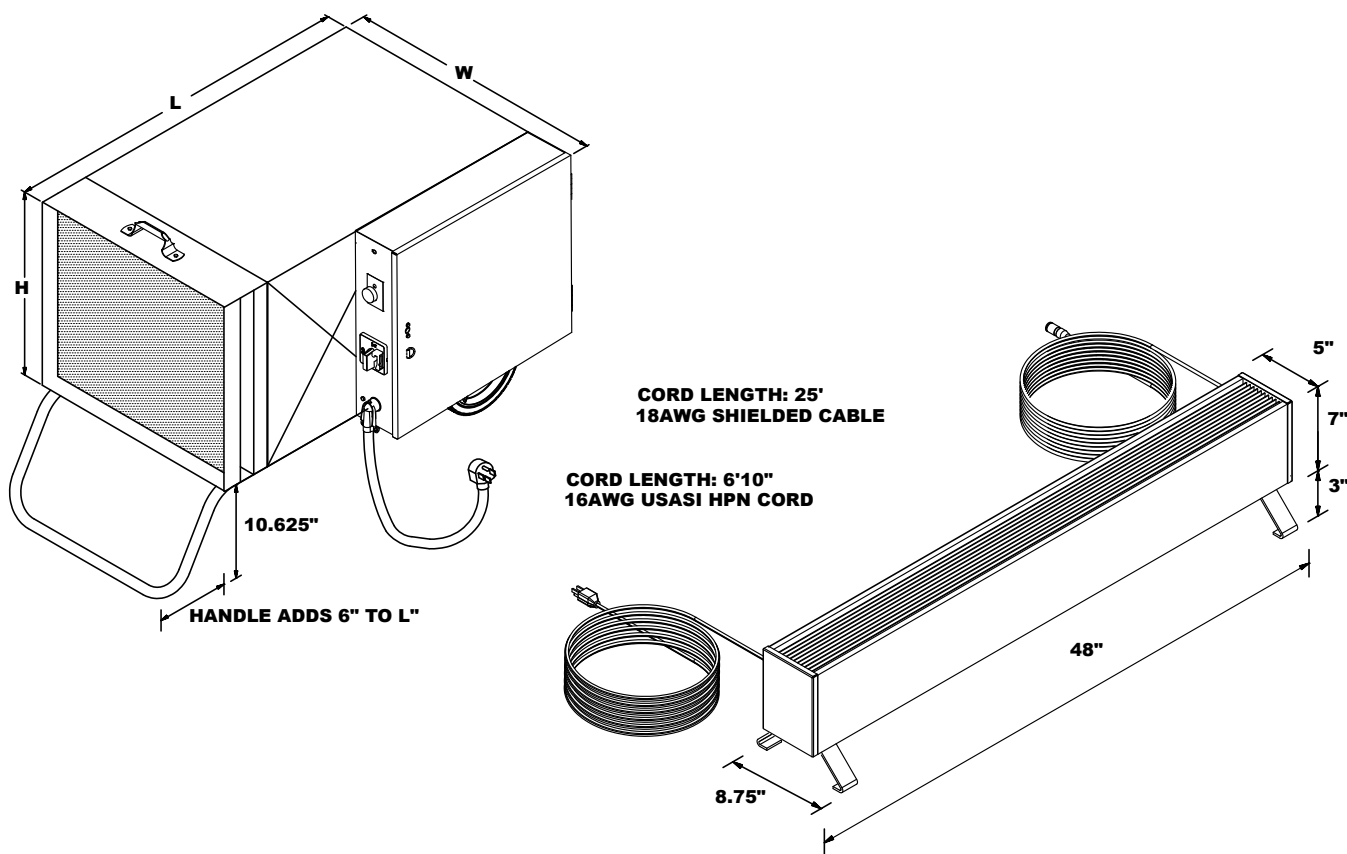

MODEL	DIMENSIONS			WT. (LBS)
	LENGTH	WIDTH	HEIGHT	
TAT-8-240-1	39"	26.5"	18"	180
TAT-5-240-1	39"	26.5"	18"	180
TAT-20-480-3	39"	30.5	18"	234
TAT-1-120-1	48"	8.5"	9.5"	23
Remote Timer	11"	3"	4.5"	5

Thermal Area Treatment Heaters

How It Works:

88

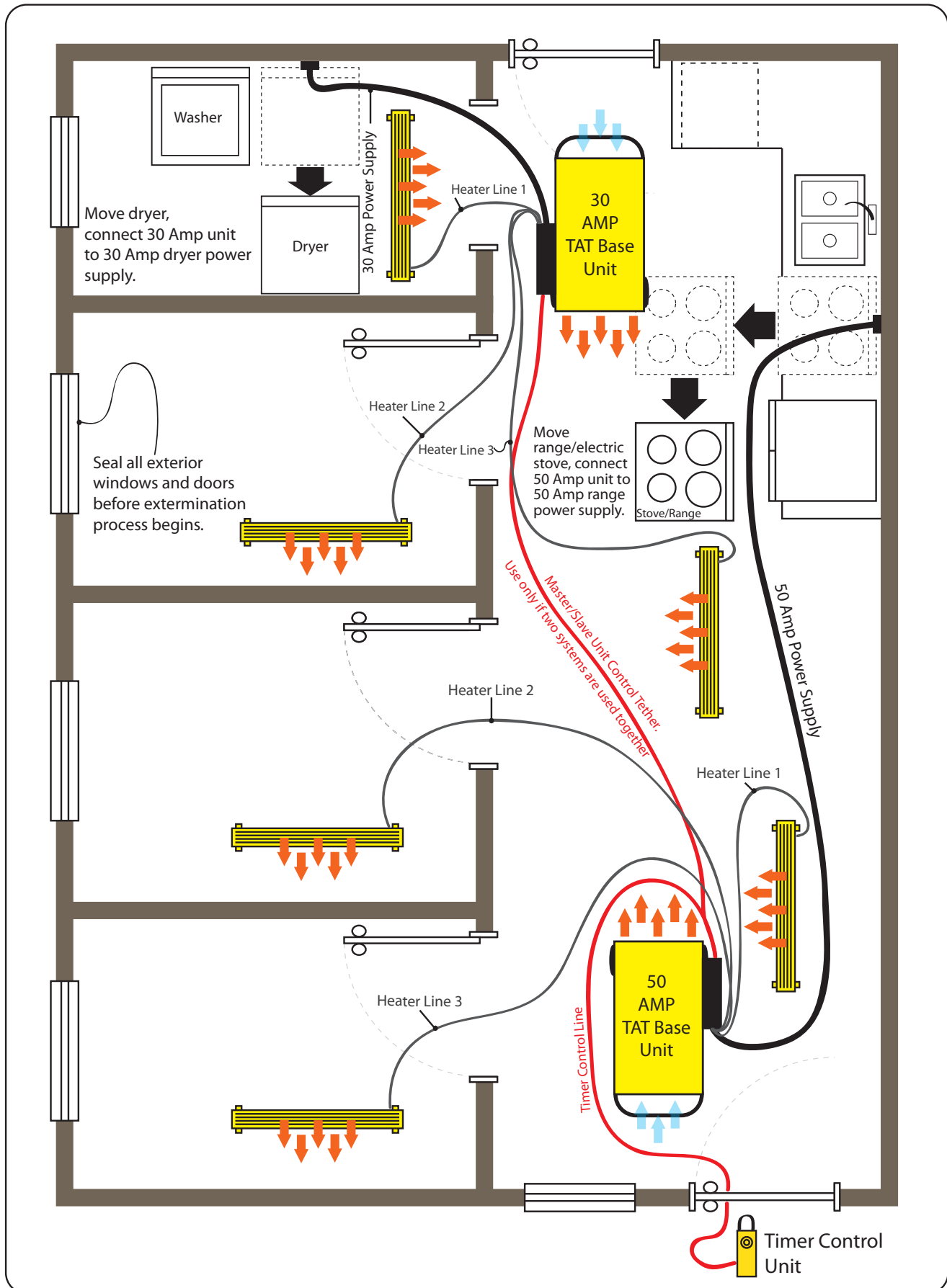

Diagram is for demonstrative purposes only and does not represent any actual structure or living environment. Two units may not be required for all situations, exterior climate, structure insulation, electrical service, and square footage all factor into effective treatment with this system.